

Split collar (two-parts) "DUEPI" DN65-DN1200

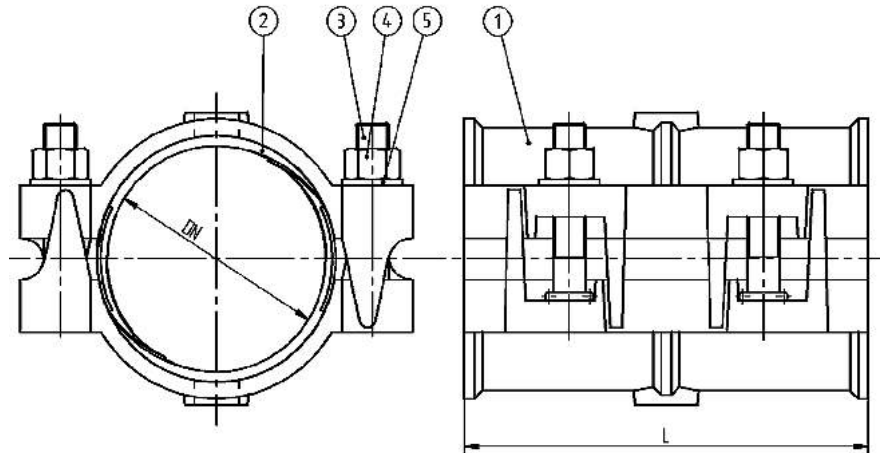

USE:

- Connections and repairs to pipes made of different materials.

MATERIALS:

- 1 - body - ductile cast iron protected with epoxy powder coating,
- 2 - gasket - EPDM or NBR rubber,
- 3-5 - galvanized steel,
- optional: nuts and bolts - stainless steel.

The product has been certified as suitable for contact with potable water.

DN	Diameter [mm] $D_{min} - D_{max}$	Weight [kg]	Number of bolts	Length [mm] L	Product code
65	75 - 84	6,00	4xM12	200	
80	92 - 103	6,50	4xM16	200	
100	115 - 126	7,10	4xM16	200	
125	141 - 154	8,00	4xM16	200	
150	166 - 182	9,50	4xM16	200	
200	216 - 226	11,00	4xM16	200	

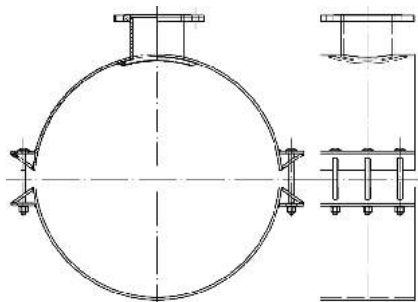

We also use engineering steel to make DN 200 - DN 1200 two-part split collars, flanged two-part split collars, adapters to connect different pipe sizes, and other untypical pipe fittings.