

Split collar (three parts) "TREPI"

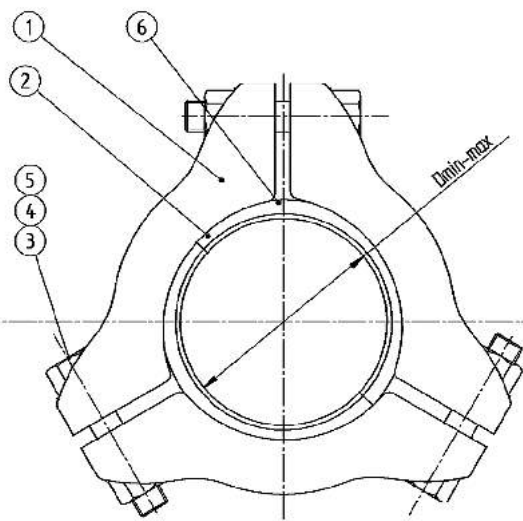
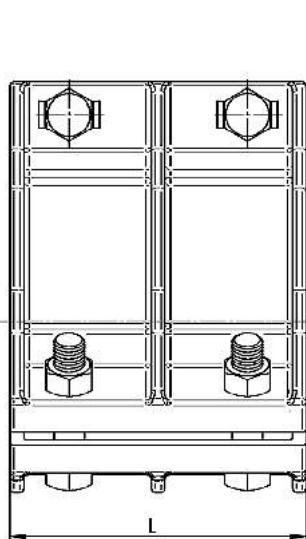

USE:

- Connections and repair pipes made of various materials.

MATERIALS:

- 1 - body - ductile cast iron protected with epoxy powder coating,
- 2 - gasket - EPDM or NBR rubber,
- 3-5 - galvanized steel,
- optional: nuts and bolts - stainless steel.

The product has been certified as suitable for contact with potable water.

DN	Diameter [mm] D _{min} - D _{max}	Weight [kg]	Bolts	Length [mm] L	Product code
60	65 - 82	8,00	6xM12	140	
80	87 - 106	9,50	6xM16	170	
100	108 - 126	11,50	6xM16	170	
125	135 - 160	19,00	6xM16	185	
150	159 - 184	18,00	6xM16	220	
175	190 - 220	20,00	9xM16	275	
200	210 - 240	23,00	9xM16	275	
225	240 - 255	24,00	9xM16	280	
250	250 - 288	60,00	9xM20	365	
275	290 - 312	65,00	9xM20	365	
300	312-345 or 302-335	72,00	12XM20	420	
350	360-390 or 350-380	90,00	12XM20	425	
400	410-460 or 400-450	107,00	12XM20	430	
450	460-510 or 450-500	115,00	12XM20	420	
500	510-570 or 500-560	130,00	12XM20	420	
550	570-620 or 560-610	135,00	12XM20	420	
600	620-680 or 610-670	140,00	12XM20	420	
700	730-800 or 720-790	160,00	12XM20	420	
800	810-860 or 800-850	180,00	12XM20	420	